

## Chapter 2 The Common Cathode Gain Stage with grounded Cathode (CCS+C<sub>c</sub>)

---

### 2.1 Circuit diagram

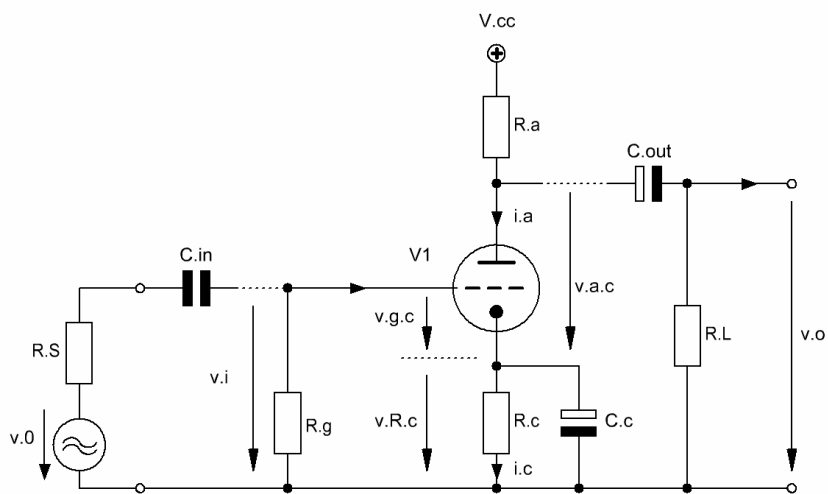

Figure 2.1 Basic design of the Common Cathode Gain Stage with grounded Cathode via  $C_c$  (CCS+C<sub>c</sub>)

---

## 2.2 Basic formulae (excl. stage load ( $R_L$ )-effect)

2.2.1 gain  $G_t$  ( $C_c$  acts as a complete short-circuit):

$$G_t = -\frac{V_o}{V_i} \quad (2.1)$$

gain  $G_t$  in terms of  $g_{m,t}$  and  $\mu_t$  becomes:

$$\begin{aligned} G_t &= -g_{m,t} \frac{r_{a,t} R_a}{r_{a,t} + R_a} \\ &= -\mu_t \frac{R_a}{r_{a,t} + R_a} \end{aligned} \quad (2.2)$$

2.2.2 grid input resistance  $R_g$ , input capacitance  $C_{i,tot}$  and input impedance  $Z_{i,g}(f)$ :

$$Z_{i,g}(f) = R_g \parallel C_{i,tot} \quad (2.3)$$

formulae for  $C_{i,tot}$ : see Chapter 1

2.2.3 plate output resistance  $R_{o,a}$  and output impedance  $Z_{o,a}(f)$ :

$$R_{o,a} = r_{a,t} \parallel R_a \quad (2.4)$$

$$Z_{o,a}(f) = R_{o,a} \parallel C_{o,tot} \quad (2.5)$$

formulae for  $C_o$ : see Chapter 1

2.2.4 cathode output resistance  $R_{o,c}$ :

$$\begin{aligned} R_{o,c} &= r_{c,t} \parallel R_c \\ r_{c,t} &= \frac{r_{a,t} + R_a}{1 + \mu_t} \end{aligned} \quad (2.6)$$

2.2.5 capacitance  $C_c$  for a specific hp corner frequency  $f_{c,opt}$ :

$$C_c = \frac{1}{2\pi f_{c,opt} R_{o,c}} \quad (2.7)$$

**2.3 Derivations**

2.3.1 Equivalent circuit for derivation purposes:

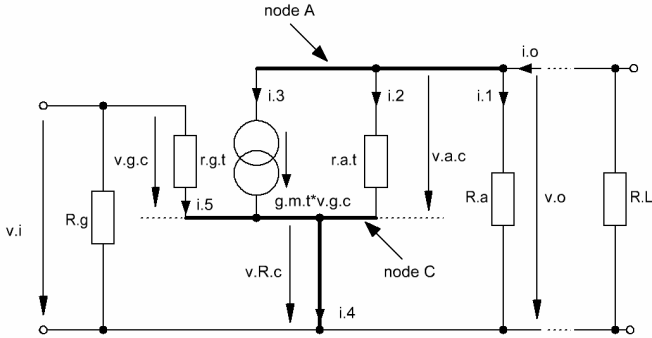

Figure 2.2 Equivalent circuit of Figure 2.1

2.3.2 Derivations:

With  $C_c$  of a size that acts as a short-circuit for  $v_{R.c}$  in  $B_{20k}$  we can use all the respective formulae of Chapter 1 with  $R_c = 0$ , hence:

2.3.2.1 the gain  $G_t$  and effective gain  $G_{t,eff}$  become:

$$G_t = -g_{m.t} (r_{a.t} \parallel R_a) \tag{2.8}$$

$$R_{a,eff} = R_a \parallel R_L \tag{2.9}$$

$$G_{t,eff} = -g_{m.t} (r_{a.t} \parallel R_{a,eff}) \tag{2.10}$$

2.3.2.2 the grid input impedance  $Z_{i.g}(f)$  becomes:

$$Z_{i.g}(f) = \left| \frac{R_g}{1 + 2j\pi f R_g C_{i,tot}} \right| \tag{2.11}$$

2.3.2.3 the effective plate output resistance  $R_{o,a,eff}$  and impedance  $Z_{o,a,eff}(f)$  become:

$$\begin{aligned} R_{o,a} &= r_{a.t} \parallel R_a \\ \Rightarrow Z_{o,a}(f) &= R_{o,a} \parallel C_{o,tot} \end{aligned} \tag{2.12}$$

$$\begin{aligned} R_{o,a,eff} &= r_{a.t} \parallel R_{a,eff} \\ \Rightarrow Z_{o,a,eff}(f) &= R_{o,a,eff} \parallel C_{o,tot} \end{aligned} \tag{2.13}$$

$$Z_{o.a.eff}(f) = \left| \frac{R_{o.a.eff}}{1 + 2j\pi f R_{o.a.eff} C_o} \right| \quad (2.14)$$

2.3.2.4 cathode resistance  $r_{c.t.eff}$ <sup>1</sup> and effective cathode output resistance  $R_{o.c.eff}$  become:

$$r_{c.t.eff} = \frac{r_{a.t} + R_{a.eff}}{1 + \mu_t} \quad (2.15)$$

$$\begin{aligned} R_{o.c.eff} &= r_{c.t.eff} \parallel R_c \\ &= \frac{\frac{r_{a.t} + R_{a.eff}}{1 + \mu_t} R_c}{\frac{r_{a.t} + R_{a.eff}}{1 + \mu_t} + R_c} \end{aligned} \quad (2.16)$$

MCD symbolic evaluation “simplify” leads to

$$R_{o.c.eff} = \frac{(r_{a.t} + R_{a.eff}) R_c}{r_{a.t} + R_{a.eff} + (1 + \mu_t) R_c} \quad (2.17)$$

2.3.2.5 cathode capacitance  $C_c$  for a specific hp corner frequency  $f_c$ :

The audio band  $B_{20k}$  spreads from 20Hz to 20kHz. To ensure a flat frequency response in  $B_{20k}$  ( $\pm 0.1$ dB) as well as a phase response deviation of less than  $1^\circ$  at  $f_c = 20$ Hz the  $C_c$  calculation should be based on a corner frequency  $f_{c,opt}$  that is a  $100^{\text{th}}$  of  $f_c$ .

$$\begin{aligned} f_c &= 20\text{Hz} \\ f_{c,opt} &= \frac{20\text{Hz}}{100} = 0.2\text{Hz} \end{aligned} \quad (2.18)$$

$$C_c = \frac{1}{2\pi f_{c,opt} R_{o.c.eff}} \quad (2.19)$$

2.3.2.6 total input capacitance  $C_{i,tot}$  and total output capacitance  $C_{o,tot}$ :

see respective equations and footnote<sup>2</sup> in Chapter 1 - 1.3.2.5

<sup>1</sup> detailed derivation see Chapter 4 “The common grid stage (CGS)”

<sup>2</sup> see footnote 2 in Chapter 1

2.4 Gain stage frequency and phase response calculations

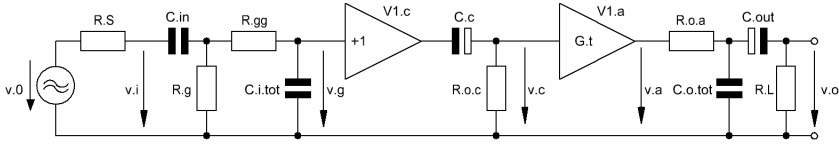

Figure 2.3 Simplified<sup>3</sup> equivalent circuit of Figure 2.1 - including all frequency and phase response relevant components

2.4.1 gain stage input transfer function  $T_i(f)$  and phase  $\phi_i(f)$  - including source resistance  $R_S$  and an oscillation preventing resistor  $R_{gg} \ll R_g$ :

see Chapter 1 - 1.4.1

2.4.2 gain stage output transfer function  $T_o(f)$  and phase  $\phi_o(f)$ :

see Chapter 1 - 1.4.2

2.4.3 gain stage cathode transfer function  $T_c(f)$  and phase  $\phi_c(f)$ :

$$T_c(f) = \left( \frac{R_{o.c.eff}}{R_{o.c.eff} + \frac{1}{2j\pi f C_c}} \right) \tag{2.20}$$

$$\phi_c(f) = \arctan \left\{ \frac{\text{Im}[T_c(f)]}{\text{Re}[T_c(f)]} \right\} \tag{2.21}$$

2.4.4 fundamental gain stage phase shift  $\phi_{G,t}(f)$ :

$$\phi_{G,t}(f) = -180^\circ \tag{2.22}$$

2.4.5 gain stage transfer function  $T_{tot}(f)$  and phase  $\phi_{tot}(f)$ :

$$T_{tot}(f) = T_i(f) T_o(f) T_c(f) G_t \tag{2.23}$$

$$\phi_{tot}(f) = \phi_i(f) + \phi_o(f) + \phi_c(f) + \phi_{G,t}(f) \tag{2.24}$$

<sup>3</sup> "Simplified" because of footnote 2 of Chapter 1. In addition: The simple  $C_c$  and  $R_{o.c}$  network after the +1 amp  $V1_c$  works correct the shown way only in the frequency range of  $f_{c,opt}$  minus one octave. In lower frequency ranges than that the gain of the whole gain stage will reach the gain of a CCS gain stage with the same components but without  $C_c$ . But this frequency range lies far outside  $B_{20k}$ .

**2.5 Example with ECC83 / 12AX7 (83):**

Figure 2.4 CCS+Cc example circuitry

**2.5.1 Triode bias data:**

$$I_{a.83} = 1.2 \cdot 10^{-3} \text{ A} \quad V_{cc.83} = 370 \text{ V} \quad V_{a.83} = 250 \text{ V} \quad V_{g.83} = -2 \text{ V}$$

**2.5.2 Triode valve constants:**

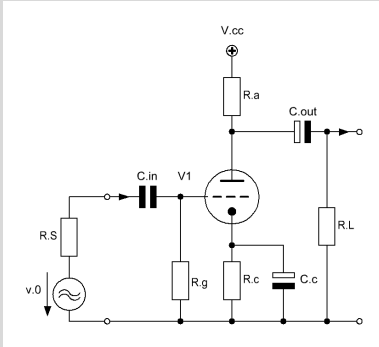
$$\begin{aligned} g_{m.83} &:= 1.6 \cdot 10^{-3} \text{ S} & \mu_{83} &:= 100 & r_{a.83} &:= 62.5 \cdot 10^3 \Omega \\ C_{g.c.83} &:= 1.65 \cdot 10^{-12} \text{ F} & C_{g.a.83} &:= 1.6 \cdot 10^{-12} \text{ F} & C_{a.c.83} &:= 0.33 \cdot 10^{-12} \text{ F} \\ C_{o.tot.83} &:= C_{a.c.83} + C_{g.a.83} & C_{o.tot.83} &:= 1.93 \cdot 10^{-12} \text{ F} \end{aligned}$$

**2.5.3 Circuit variables:**

$$\begin{aligned} R_{a.83} &:= 100 \cdot 10^3 \Omega & R_{c.83} &:= 1.6 \cdot 10^3 \Omega & R_{g.83} &:= 1 \cdot 10^6 \Omega \\ R_S &:= 1 \cdot 10^3 \Omega & R_L &:= 1 \cdot 10^6 \Omega & R_{gg.83} &:= 2.2 \cdot 10^3 \Omega \\ C_{stray.83} &:= 10 \cdot 10^{-12} \text{ F} & C_{in.83} &:= 100 \cdot 10^{-9} \text{ F} & C_{out.83} &:= 100 \cdot 10^{-9} \text{ F} \end{aligned}$$

**2.5.4 Calculation relevant data:**

frequency range  $f$  for the below shown graphs:

$$\begin{aligned} f &:= 10 \text{ Hz}, 20 \text{ Hz}, \dots, 20000 \text{ Hz} \\ h &:= 1000 \text{ Hz} \end{aligned}$$

**2.5.5 Gain  $G_t$  and effective gain  $G_{t,eff}$ :**

$$G_{83} := -g_{m.83} \frac{R_{a.83} \cdot r_{a.83}}{R_{a.83} + r_{a.83}} \quad G_{83} = -61.538 \times 10^0$$

$$G_{83,e} := 20 \cdot \log(|G_{83}|)$$

$$G_{83,e} = 35.783 \times 10^0 \text{ [dB]}$$

$$R_{a.83,\text{eff}} := \left( \frac{1}{R_{a.83}} + \frac{1}{R_L} \right)^{-1}$$

$$R_{a.83,\text{eff}} = 90.909 \times 10^3 \Omega$$

$$G_{83,\text{eff}} := -\mu_{83} \cdot \frac{R_{a.83,\text{eff}}}{R_{a.83,\text{eff}} + r_{a.83}}$$

$$G_{83,\text{eff}} = -59.259 \times 10^0$$

$$G_{83,\text{eff},e} := 20 \cdot \log(|G_{83,\text{eff}}|)$$

$$G_{83,\text{eff},e} = 35.455 \times 10^0 \text{ [dB]}$$

### 2.5.6 Specific resistances:

$$R_{o.a.83} := \left[ \left( \frac{1}{r_{a.83}} + \frac{1}{R_{a.83}} \right)^{-1} \right]$$

$$R_{o.a.83} = 38.462 \times 10^3 \Omega$$

$$R_{o.a.83,\text{eff}} := \left( \frac{1}{r_{a.83}} + \frac{1}{R_{a.83,\text{eff}}} \right)^{-1}$$

$$R_{o.a.83,\text{eff}} = 37.037 \times 10^3 \Omega$$

$$r_{c.83} := \frac{r_{a.83} + R_{a.83}}{1 + \mu_{83}}$$

$$r_{c.83} = 1.609 \times 10^3 \Omega$$

$$R_{o.c.83} := \left( \frac{1}{r_{c.83}} + \frac{1}{R_{c.83}} \right)^{-1}$$

$$R_{o.c.83} = 802.222 \times 10^0 \Omega$$

$$r_{c.83,\text{eff}} := \frac{r_{a.83} + R_{a.83,\text{eff}}}{1 + \mu_{83}}$$

$$r_{c.83,\text{eff}} = 1.519 \times 10^3 \Omega$$

$$R_{o.c.83,\text{eff}} := \left( \frac{1}{r_{c.83,\text{eff}}} + \frac{1}{R_{c.83}} \right)^{-1}$$

$$R_{o.c.83,\text{eff}} = 779.198 \times 10^0 \Omega$$

### 2.5.7 Capacitance $C_c$ :

$$f_c := 20 \text{ Hz}$$

$$f_{c,\text{opt}} := \frac{f_c}{100}$$

$$f_{c,\text{opt}} = 200 \times 10^{-3} \text{ Hz}$$

$$C_c := \frac{1}{2 \cdot \pi \cdot f_{c,\text{opt}} \cdot R_{o.c.83,\text{eff}}}$$

$$C_c = 1.021 \times 10^{-3} \text{ F}$$

### 2.5.8 Specific other capacitances:

$$C_{i,\text{tot},83} := (1 + |G_{83}|) \cdot C_{g.a.83} + C_{g.c.83} + C_{\text{stray},83}$$

$$C_{i,\text{tot},83} = 111.712 \times 10^{-12} \text{ F}$$

**2.5.9 Gain stage frequency and phase response calculations:**

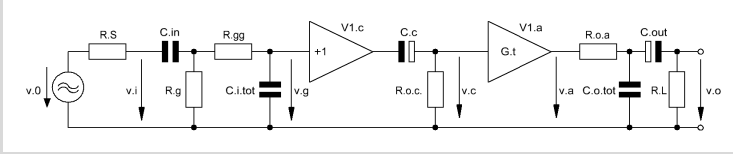

Figure 2.5 = Figure 2.3

$$Z1(f) := \frac{1}{2j \cdot \pi \cdot f \cdot C_{in.83}}$$

$$Z2(f) := \frac{1}{2j \cdot \pi \cdot f \cdot C_{i.tot.83}}$$

$$T_i(f) := \frac{Z2(f) \cdot \left( \frac{1}{R_{g.83}} + \frac{1}{R_{gg.83} + Z2(f)} \right)^{-1}}{\left( Z2(f) + R_{gg.83} \right) \left[ R_S + Z1(f) + \left( \frac{1}{R_{g.83}} + \frac{1}{R_{gg.83} + Z2(f)} \right)^{-1} \right]} \quad \phi_i(f) := \text{atan} \left( \frac{\text{Im}(T_i(f))}{\text{Re}(T_i(f))} \right)$$

$$T_{i.e}(f) := 20 \cdot \log(|T_i(f)|)$$

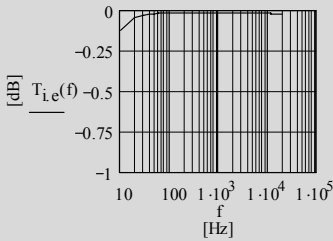

Figure 2.6 Transfer of i/p network

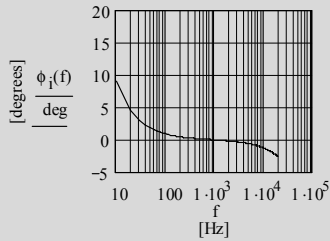

Figure 2.7 Phase of i/p network

$$Z3(f) := \frac{1}{2j \cdot \pi \cdot f \cdot C_{o.tot.83}}$$

$$Z4(f) := \frac{1}{2j \cdot \pi \cdot f \cdot C_{out.83}}$$

$$T_o(f) := \frac{\left( \frac{1}{Z3(f) + Z4(f) + R_L} \right)^{-1} \cdot R_L}{R_{o.a.83} + \left( \frac{1}{Z3(f) + Z4(f) + R_L} \right)^{-1}} \quad \phi_o(f) := \text{atan} \left( \frac{\text{Im}(T_o(f))}{\text{Re}(T_o(f))} \right)$$

$$T_{o.e}(f) := 20 \cdot \log(|T_o(f)|)$$



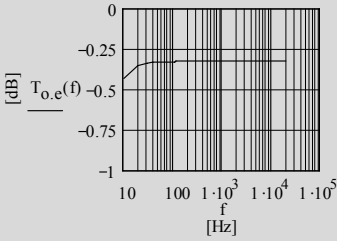

Figure 2.8 Transfer of cathode network

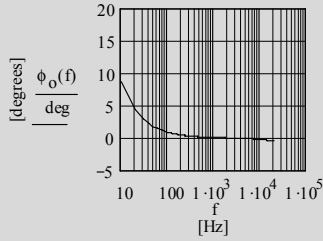

Figure 2.9 Phase of cathode network

$$T_c(f) := \left( \frac{R_{o.c.83.eff}}{R_{o.c.83.eff} + \frac{1}{2j \cdot \pi \cdot f \cdot C_c}} \right)$$

$$\phi_c(f) := \text{atan} \left( \frac{\text{Im}(T_c(f))}{\text{Re}(T_c(f))} \right)$$

$$T_{c.e}(f) := 20 \cdot \log(|T_c(f)|)$$

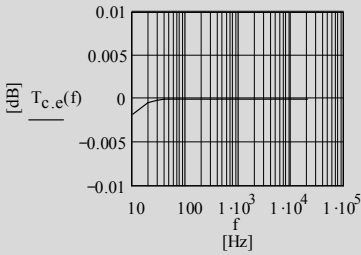

Figure 2.10 Transfer of o/p network

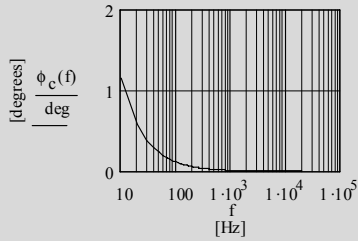

Figure 2.11 Phase of o/p network

$$T_{tot.83}(f) := T_i(f) \cdot T_o(f) \cdot T_c(f) \cdot G_{83}$$

$$\phi_{G.83}(f) := -180 \text{ deg}$$

$$T_{tot.83.e}(f) := 20 \cdot \log(|T_{tot.83}(f)|)$$

$$\phi_{tot.83}(f) := \phi_i(f) + \phi_o(f) + \phi_c(f) + \phi_{G.83}(f)$$

**2.2.10 Frequency and phase response plots:**

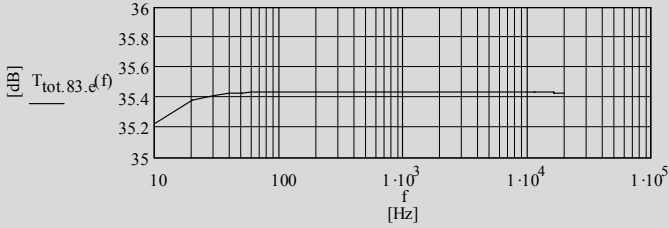

Figure 2.12 Frequency response of the whole CCS+Cc gain stage

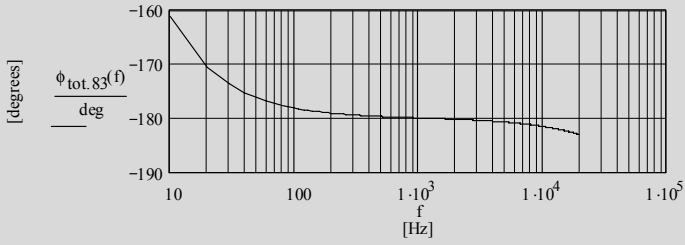

Figure 2.13 Phase response of the whole CCS+Cc gain stage